

SERIES 5000

non-metallic flexible fan connectors

The Series 520, Series 530, and Series 540 non-metallic connectors are designed to match inlet and outlet flanges of most industrial fan manufacturers and are found in: Ventilating Systems, Industrial Process Ducting Systems, Chemical-Petrochemical Plants, Power Generating Plants, Pulp/Paper Plants, Water-Waste Water Sewage and Odor Control Ducting Systems. Specify the Series 520, Series 530 and Series 540 non-metallic connectors for installation between anchor points or next to mechanical equipment such as: Fans, Blowers, Compressors and Hot Air Ducts. The Series 500 non-metallic flexible connectors are designed to: (1) Absorb Ducting Movements, (2) Reduce System Noise, (3) Isolate Vibration, (4) Compensate Alignment/Offset. Our history in the manufacture of expansion joint products dates back to 1930.

Engineered For Your Application: The Series 500 non-metallic connectors are available in U-Designs, Arch-Designs and W-Designs. Each style offers different movement and pressure ratings to fit required specification. Available styles include:

- **Style 520:** Known as a U-Type, this integrally flanged non-metallic connector is found in applications where large movements are required and where vibration and sound absorption are needed. This non-metallic fan connector can be manufactured in both round and rectangular shapes.
- **Style 530:** Known as an Arch-Type, this integrally flanged non-metallic connector is found in applications where large movements and short overall lengths are required. Primarily used for Clean Hot Air/Gas Service, the Style 530 is designed with a high profile molded arch, giving it exceptional movement capabilities. This non-metallic connector can be manufactured in both round and rectangular shapes.
- **Style 540:** Known as a W-Type, this integrally flanged non-metallic connector is found in applications where large movements are required for Standard Hot Air/Gas Service. The Style 540 is designed with a molded radius allowing for greater movement capability and should be used when the U-Type (520) does not meet movement specifications. This non-metallic connector can be manufactured in both round and rectangular shapes.
- **Other Styles Available Include:** Style 501 (Flat Belt Type), Style 502 (Flat Belt Arch-Type) and 190-K Navy Fan Connector (U-Type or Arch-Type). These styles are included in this brochure.

Retaining Rings/Backing Bars. Retaining rings (round) or backing bars (rectangular) are required for Series 500 non-metallic connectors and can be furnished upon request. Standard construction calls for 2" wide by 3/8" thick carbon steel bars drilled to customer specifications. Other materials of construction can be provided upon request. In addition, we can also supply T-Bolt Latch Clamps for round applications under 20" ID.

Available Fabric Materials. We can manufacture the Series 500 non-metallic connectors in a wide selection of materials which include Chlorobutyl, Neoprene, Hypalon®, EPDM and Viton®. Material selection is dependent upon application.

Hypalon and Viton are registered trademarks of DuPont Dow Elastomers.

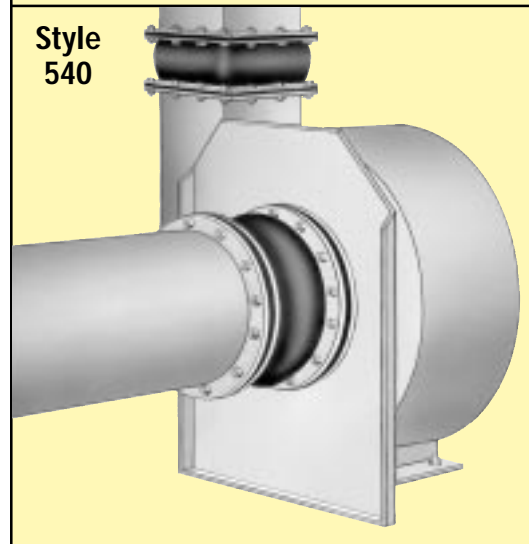
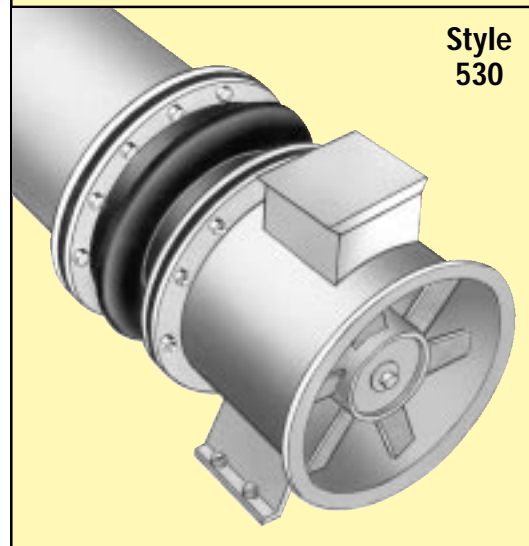
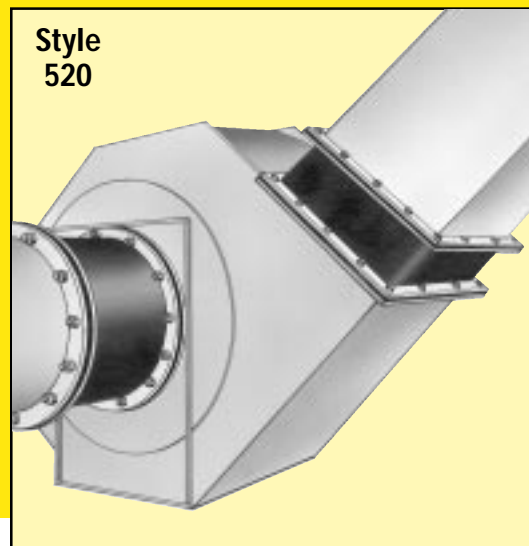

The Expansion Joint People

*Protecting Ducting And
Equipment Systems
From Stress/Motion*



STYLE 520

U-DESIGN for standard movements

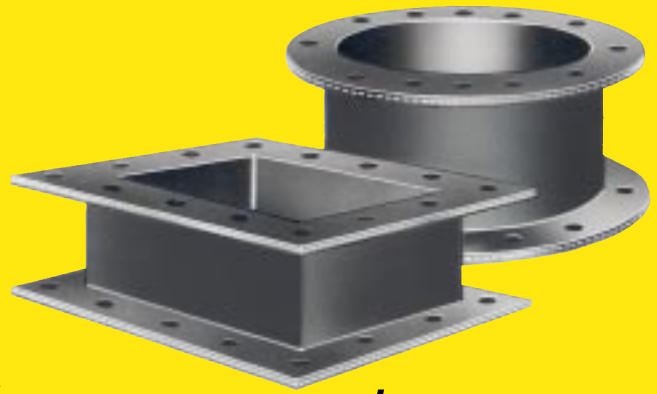

Style 520 U-Type Fan/Duct Connectors: The most economical of the integrally flanged designs, the Style 520 is predominately used for fan vibration applications. The fan/duct connector is manufactured in a U-Design configuration with a minimum of one (1) to two (2) plies of reinforced fabric vulcanized into a homogeneous product that is 3/16", 1/4" or 3/8" thick. The Style 520 is manufactured with continuous corners. No splices will be made in the corner areas. Listed below is information regarding the Style 520 non-metallic fan/duct connectors:

System Design Considerations: In designing the Series 500, Style 520 non-metallic fans/duct connector, several considerations must be taken into account to ensure long lasting service.

- **System Media:** The designer and/or requesting party should define the system media to determine the correct elastomer for each application. Evaluation of the gas/air composition should be made during design of the non-metallic fan/duct connector. Abrasion characteristics and external environment conditions should also be taken into account when specifying the fabric element.
- **System Temperature:** The system operating temperature is of primary importance to the design of a non-metallic fan/duct connector, although the system design is generally specified. It is important to distinguish between operating and design as "design" can include a significant safety factor which may result in an upgraded material or design selection.
- **System Pressure:** Normal operating pressures and maximum pressures (positive and negative) under upset conditions should be specified. Combinations of pressures and temperatures should be specifically identified.
- **Movements:** Movements consist of thermal growth resulting from both operating and upset conditions. Individual movements resulting from both conditions should be specified. Maximum installation misalignment should also be taken into account to determine if the non-metallic fan/duct connector design is capable of reacting to a combination of the total maximum movements.

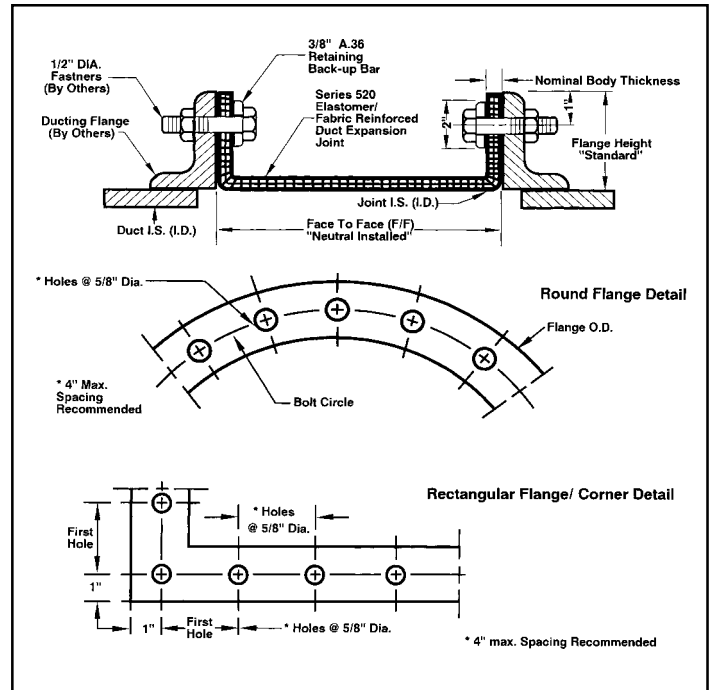

Style 520 Available Materials						
Styles	Material Code	Elastomer	Nominal Body Thickness	No. of Reinforcement Plies	Maximum Operating Temp °F	Maximum Pressure Rating (PSI)
520	BB	Chlorobutyl	3/16"	1	300°	±2
	EE	EPDM			300°	
	HH	Hypalon®	1/4"	2	225°	
	NH	Neoprene/Hypalon®			225°	
	NN	Neoprene	3/8"	2	212°	
	NP	Neoprene/Buna-N			212°	
	VV	Viton®	400°			

NOTES: 1. Hypalon and Viton are registered trademarks of DuPont Dow Elastomers
 2. Expansion Joint "Cover" (outside) can be Hypalon painted on special order.
 3. Standard fabric reinforcement is polyester. Other high temperature materials are available upon request.
 4. For vacuum applications, all fabric elements should retain sufficient setback from the duct to ensure that belting does not protrude into the flow stream.

Non-Metallic Fan/Duct Connector Weight (pounds per square foot of periphery)								
Nominal Body Thickness	Elastomers							Retaining Rings/Bars Linear/Foot
	Chloro-butyl	EPDM	Hypalon®	Neoprene/Hypalon®	Neoprene	Neoprene/Buna-N	Viton®	
1/4"	1.6	1.6	1.8	1.8	1.8	1.8	2.5	3.5
3/8"	2.5	2.5	2.6	2.6	2.6	2.6	4.8	

Maximum Movement Capabilities								
6" Face To Face			9" Face To Face			12" Face To Face		
Axial Compression (inches)	Axial Extension (inches)	Lateral Offset (inches)	Axial Compression (inches)	Axial Extension (inches)	Lateral Offset (inches)	Axial Compression (inches)	Axial Extension (inches)	Lateral Offset (inches)
.75	.25	.50	1.25	.25	.75	2.0	.50	1.0

NOTES: 1. Lateral Offsets shown above are based on movements prior to axial compression. Greater lateral offset may be obtained if the fan/duct connector encounters simultaneous compression.
 2. Axial extension may be increased by pre-compression of the fan/duct connector during installation. any pre-compression of the fan/duct connector will equally reduce the rated axial compression movement.

Design Data Sheet Fan/Duct Connector - Style 520		
Item	Tag No.:	
	Quantity:	
Application	Equipment Adjacent The Connector:	
	Media: Gas or Air (circle one)	G A
Size	Location of Joint: (Inlet, Discharge, Bypass)	
	Duct I.S. or Diameter:	
Temperature	Face To Face:	IN.
	Operating:	°F
Pressure	Design:	°F
	Operating:	PSI
Movements	Design:	PSI
	Axial Compression:	IN.
	Axial Extension:	IN.
	Lateral Offset:	IN.

STYLE 530

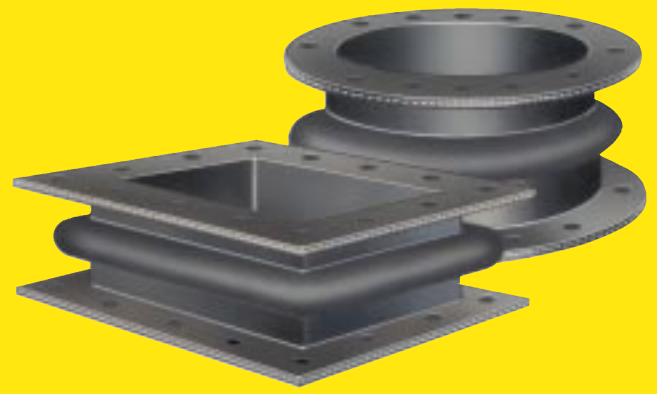

ARCH-DESIGN for ultra high movements

Style 530 Arch-Type Duct Connectors: The least economical of the integrally flanged designs, the Style 530 is predominately used for applications where movements are large and face-to-face space is a premium. The duct connector is manufactured in an Arch-Design configuration with a minimum of one (1) to two (2) plies of reinforced fabric vulcanized into a homogeneous product that is 3/16", 1/4" or 3/8" thick. The flanges shall be an integral part of the expansion joint. The Style 530 is manufactured with a premolded arch. The arch continues through the corner and straight sections and shall be fully developed when in the neutral installation position. Listed below is information regarding the Style 530 non-metallic duct connectors:

System Design Considerations: In designing the Series 500, Style 530 non-metallic duct connector, several considerations must be taken into account to ensure long lasting service.

- **System Media:** The designer and/or requesting party should define the system media to determine the correct elastomer for each application. Evaluation of the gas/air composition should be made during design of the non-metallic fan/duct connector. Abrasion characteristics and external environment conditions should also be taken into account when specifying the fabric element.
- **System Temperature:** The system operating temperature is of primary importance to the design of a non-metallic fan/duct connector, although the system design is generally specified. It is important to distinguish between operating and design as "design" can include a significant safety factor which may result in an upgraded material or design selection.
- **System Pressure:** Normal operating pressures and maximum pressures (positive and negative) under upset conditions should be specified. Combinations of pressures and temperatures should be specifically identified.
- **Movements:** Movements consist of thermal growth resulting from both operating and upset conditions. Individual movements resulting from both conditions should be specified. Maximum installation misalignment should also be taken into account to determine if the non-metallic fan/duct connector design is capable of reacting to a combination of the total maximum movements.

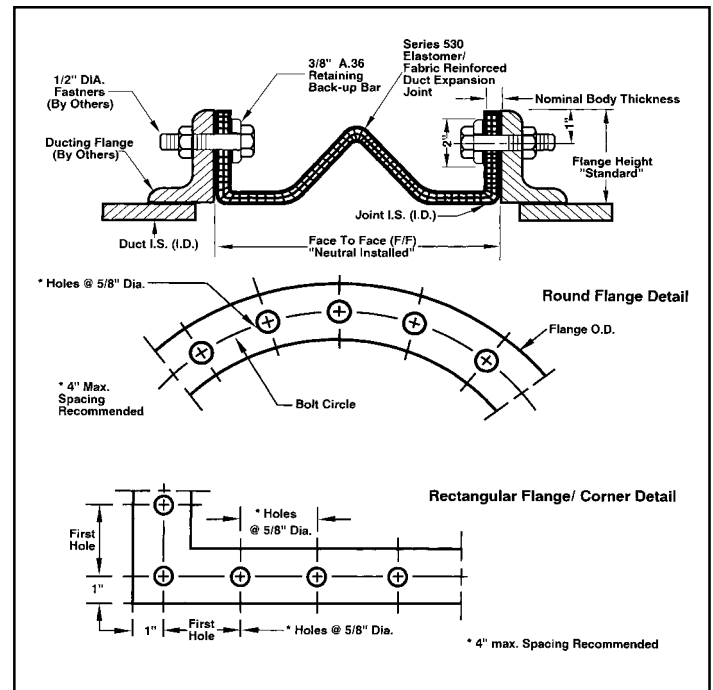

Style 530 Available Materials						
Styles	Material Code	Elastomer	Nominal Body Thickness	No. of Reinforcement Plies	Maximum Operating Temp °F	Maximum Pressure Rating (PSI)
530	BB	Chlorobutyl	3/16"	1	300°	±2
	EE	EPDM			300°	
	HH	Hypalon®	1/4"	2	225°	
	NH	Neoprene/Hypalon®			225°	
	NN	Neoprene	3/8"	2	212°	
	NP	Neoprene/Buna-N			212°	
	VV	Viton®	400°			

NOTES: 1. Hypalon and Viton are registered trademarks of DuPont Dow Elastomers
 2. Expansion Joint "Cover" (outside) can be Hypalon painted on special order.
 3. Standard fabric reinforcement is polyester. Other high temperature materials are available upon request.
 4. For vacuum applications, all fabric elements should retain sufficient setback from the duct to ensure that belting does not protrude into the flow stream.

Non-Metallic Fan/Duct Connector Weight (pounds per square foot of periphery)								
Nominal Body Thickness	Elastomers							Retaining Rings/Bars Linear/Foot
	Chloro-butyl	EPDM	Hypalon®	Neoprene/Hypalon®	Neoprene	Neoprene/Buna-N	Viton®	
1/4"	1.6	1.6	1.8	1.8	1.8	1.8	2.5	3.5
3/8"	2.5	2.5	2.6	2.6	2.6	2.6	4.8	

Maximum Movement Capabilities								
6" Face To Face			9" Face To Face			12" Face To Face		
Axial Compression (inches)	Axial Extension (inches)	Lateral Offset (inches)	Axial Compression (inches)	Axial Extension (inches)	Lateral Offset (inches)	Axial Compression (inches)	Axial Extension (inches)	Lateral Offset (inches)
2.25	1.25	1.25	2.75	1.5	1.5	3.5	2.0	2.0

NOTES: 1. Lateral Offsets shown above are based on movements prior to axial compression. Greater lateral offset may be obtained if the fan/duct connector encounters simultaneous compression.
 2. Axial extension may be increased by pre-compression of the fan/duct connector during installation. any pre-compression of the fan/duct connector will equally reduce the rated axial compression movement.

Design Data Sheet Fan/Duct Connector - Style 530			
Item	Tag No.:		
	Quantity:		
Application	Equipment Adjacent The Connector:		
	Media: Gas or Air (circle one)	G	A
Size	Location of Joint: (Inlet, Discharge, Bypass)		
	Duct I.S. or Diameter:		
Temperature	Face To Face:	IN.	
	Operating:	°F	
Pressure	Design:	°F	
	Operating:	PSI	
Movements	Design:	PSI	
	Axial Compression:	IN.	
	Axial Extension:	IN.	
	Lateral Offset:	IN.	

STYLE 540

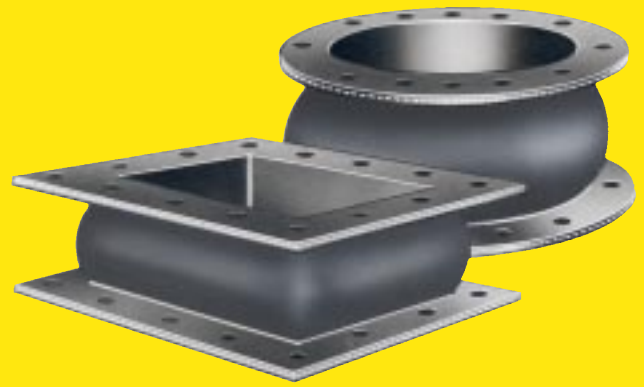

W-DESIGN for maximum movements

Style 540 W-Type Duct Connectors: An economical integrally flanged design, the Style 540 is predominately used for applications where there are large movements. The duct connector is manufactured in a W-Design configuration with a minimum of one (1) to two (2) plies of reinforced fabric vulcanized into a homogeneous product that is 3/16", 1/4" or 3/8" thick. The flanges shall be an integral part of the expansion joint. The Style 540 is manufactured with a premolded arch. The arch continues through the corner and shall be fully developed when in the neutral position. Listed below are considerations regarding the design of the Style 540 non-metallic duct connectors:

System Design Considerations: In designing the Series 500, Style 540 non-metallic duct connector, several considerations must be taken into account to ensure long lasting service.

- **System Media:** The designer and/or requesting party should define the system media to determine the correct elastomer for each application. Evaluation of the gas/air composition should be made during design of the non-metallic fan/duct connector. Abrasion characteristics and external environment conditions should also be taken into account when specifying the fabric element.
- **System Temperature:** The system operating temperature is of primary importance to the design of a non-metallic fan/duct connector, although the system design is generally specified. It is important to distinguish between operating and design as "design" can include a significant safety factor which may result in an upgraded material or design selection.
- **System Pressure:** Normal operating pressures and maximum pressures (positive and negative) under upset conditions should be specified. Combinations of pressures and temperatures should be specifically identified.
- **Movements:** Movements consist of thermal growth resulting from both operating and upset conditions. Individual movements resulting from both conditions should be specified. Maximum installation misalignment should also be taken into account to determine if the non-metallic fan/duct connector design is capable of reacting to a combination of the total maximum movements.

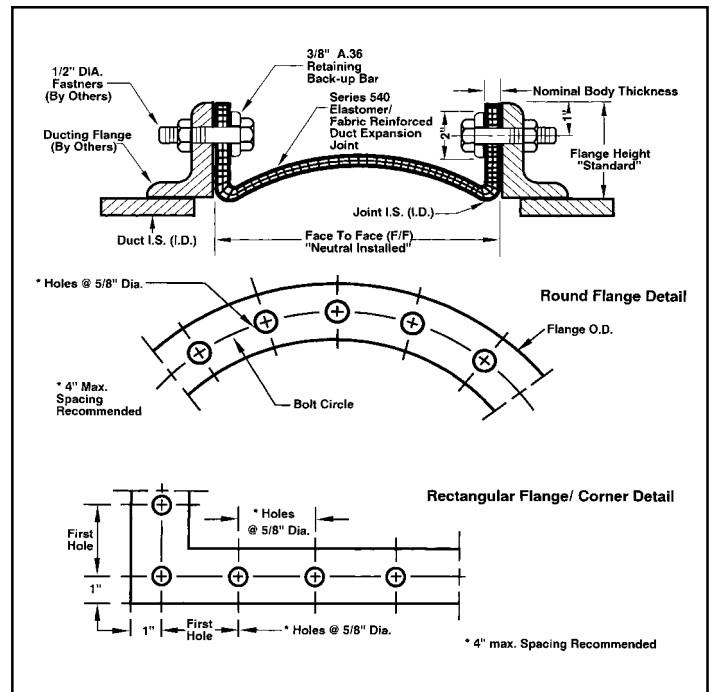

Style 540 Available Materials						
Styles	Material Code	Elastomer	Nominal Body Thickness	No. of Reinforcement Plies	Maximum Operating Temp °F	Maximum Pressure Rating (PSI)
540	BB	Chlorobutyl	3/16"	1	300°	±2
	EE	EPDM			300°	
	HH	Hypalon®	1/4"	2	225°	
	NH	Neoprene/Hypalon®			225°	
	NN	Neoprene	3/8"	2	212°	
	NP	Neoprene/Buna-N			212°	
	VV	Viton®	400°			

NOTES: 1. Hypalon and Viton are registered trademarks of DuPont Dow Elastomers
 2. Expansion Joint "Cover" (outside) can be Hypalon painted on special order.
 3. Standard fabric reinforcement is polyester. Other high temperature materials are available upon request.
 4. For vacuum applications, all fabric elements should retain sufficient setback from the duct to ensure that belting does not protrude into the flow stream.

Non-Metallic Fan/Duct Connector Weight (pounds per square foot of periphery)								
Nominal Body Thickness	Elastomers							Retaining Rings/Bars Linear/Foot
	Chloro-butyl	EPDM	Hypalon®	Neoprene/Hypalon®	Neoprene	Neoprene/Buna-N	Viton®	
1/4"	1.6	1.6	1.8	1.8	1.8	1.8	2.5	3.5
3/8"	2.5	2.5	2.6	2.6	2.6	2.6	4.8	

Maximum Movement Capabilities								
6" Face To Face			9" Face To Face			12" Face To Face		
Axial Compression (inches)	Axial Extension (inches)	Lateral Offset (inches)	Axial Compression (inches)	Axial Extension (inches)	Lateral Offset (inches)	Axial Compression (inches)	Axial Extension (inches)	Lateral Offset (inches)
1.5	.50	.75	2.0	.75	1.5	3.75	1.0	2.5

NOTES: 1. Lateral Offsets shown above are based on movements prior to axial compression. Greater lateral offset may be obtained if the fan/duct connector encounters simultaneous compression.
 2. Axial extension may be increased by pre-compression of the fan/duct connector during installation. any pre-compression of the fan/duct connector will equally reduce the rated axial compression movement.

Design Data Sheet Fan/Duct Connector - Style 540		
Item	Tag No.:	
	Quantity:	
Application	Equipment Adjacent The Connector:	
	Media: Gas or Air (circle one)	G A
Size	Location of Joint: (Inlet, Discharge, Bypass)	
	Duct I.S. or Diameter:	
Temperature	Face To Face:	IN.
	Operating:	°F
Pressure	Design:	°F
	Operating:	PSI
Movements	Design:	PSI
	Axial Compression:	IN.
	Axial Extension:	IN.
	Lateral Offset:	IN.

SERIES 5000

non-metallic flexible fan/duct connectors

**Style 501
flat belt type**

**Style 502
flat belt arch-type**

**Style 190-K
navy fan connector**

Style 501: Known as a "Flat Belt Type", this non-metallic connector is primarily used for low pressure vibration applications and can be attached to existing metal frames or duct work. The Series 500, Style 501 duct connector can be manufactured in round or rectangular shapes and can be attached to metal surfaces using clamps (round applications), or backing bars (rectangular applications). The Style 501 can be manufactured in a variety of elastomers and can be sent to the field spliced endless and/or prepared for cold field splice. See Table 1 for material considerations.

Style 502: Known as a "Flat Belt Arch-Type", this non-metallic connector is used for low pressure applications where movements are required and can be attached to existing metal frames or duct work. The Series 500, Style 502 duct connector can be manufactured in round or rectangular shapes and can be attached to metal surfaces using clamps (round applications), retaining rings (round applications), or backing bars (rectangular applications). The Style 502 Flat Belt Arch-Type can be manufactured in a variety of elastomers and can be sent to the field in an endless connection only. See Table 1 for material considerations.

Style 190-K: Known as a "Navy Fan Connector", the Style 190K is manufactured of 3/16" thick polyester fabric reinforced neoprene MIL-R-6855, Class 2, Durometer 40. The Style 190-K Navy Fan Connector can be manufactured in U-Type or Arch-Type forms depending upon application requirements. U-Type connectors can be manufactured with a minimum 3" face-to-face overall length. Arch-Type connectors can be manufactured with a minimum 6" face-to-face overall length. We can manufacture the Series 500, Style 190-K in both round and rectangular shapes. If flange drilling is required for the Style 190-K Navy Fan Connectors, we can drill per customer's specifications. Retaining rings and/or backing bars can be furnished (drilled or undrilled) upon request. See Table 1 for material considerations.

Table 1: Available Styles /Materials

Styles	Material Code	Elastomer	Nominal Body Thickness	No. of Reinforcement Plies	Maximum Pressure Rating (PSI)
501	BB	Chlorobutyl	3/16"	1	±1
	EE	EPDM			
	HH	Hypalon®	1/4"	2	±2
	NH	Neoprene/Hypalon®			
	NN	Neoprene			
	NP	Neoprene/Buna-N			
VV	Viton®	3/8"	2	±2	
502	BB	Chlorobutyl	3/16"	1	±1
	EE	EPDM			
	HH	Hypalon®	1/4"	2	±2
	NH	Neoprene/Hypalon®			
	NN	Neoprene			
	NP	Neoprene/Buna-N			
VV	Viton®	3/8"	2	±2	
190-K	NN	Neoprene	3/16"	1	±2
	VV	Viton®			

NOTES: 1. Hypalon and Viton are registered trademarks of DuPont Dow Elastomers
 2. Expansion Joint "Cover" (outside) can be Hypalon painted on special order.
 3. Standard fabric reinforcement is polyester. Other high temperature materials are available upon request.
 4. For vacuum applications, all fabric elements should retain sufficient setback from the duct to ensure that belting does not protrude into the flow stream.

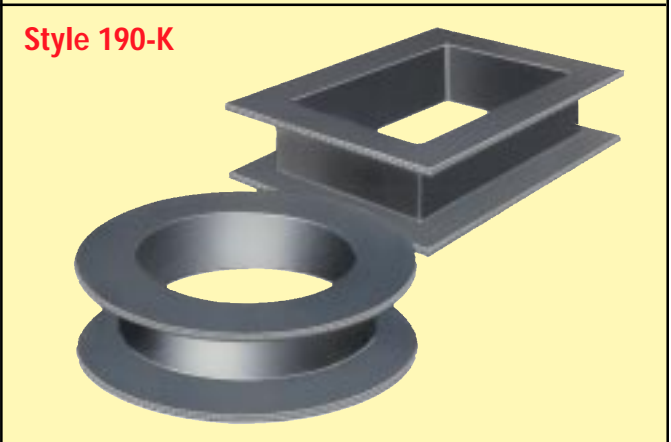
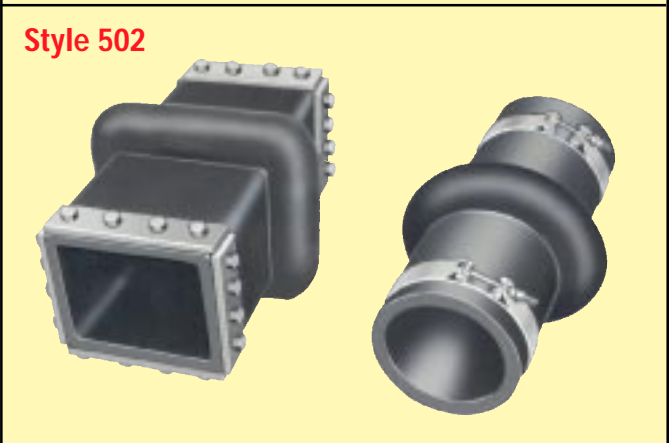
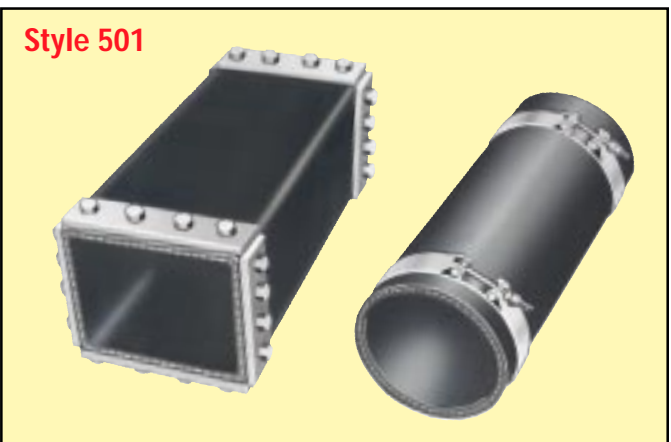

Maine Industrial Plastics and Rubber Corporation

21 Teague Street - PO Box 381 - Newcastle, ME 04553

Phone: (207) 563-5532 Email: info@miprcorp.com FAX: (207) 563-8457